



**HERBORNER
PUMPENTECHNIK**

UNIPUMP

Close coupled sewage pump



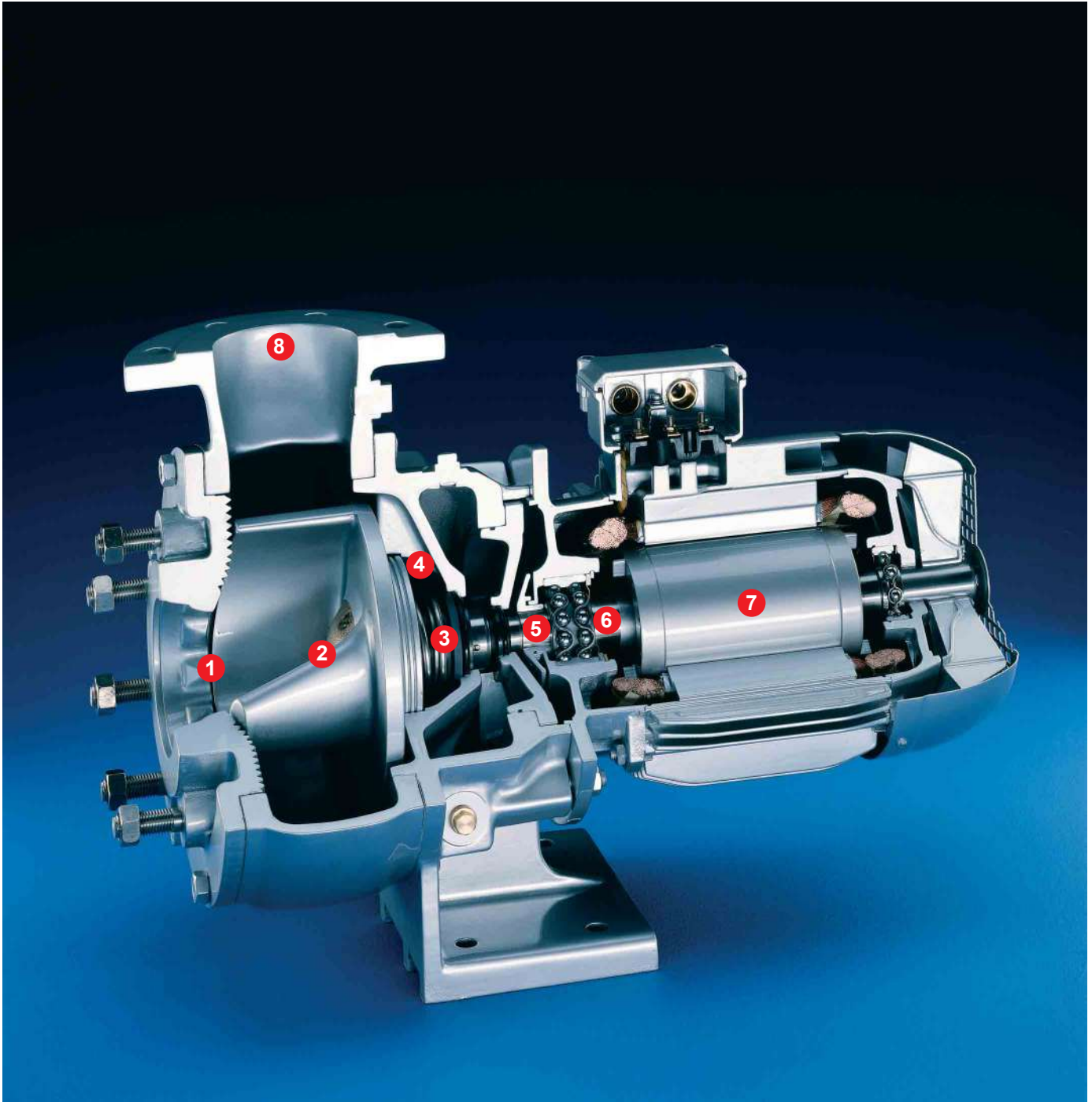

Construction of the double-acting mechanical seal (GD)

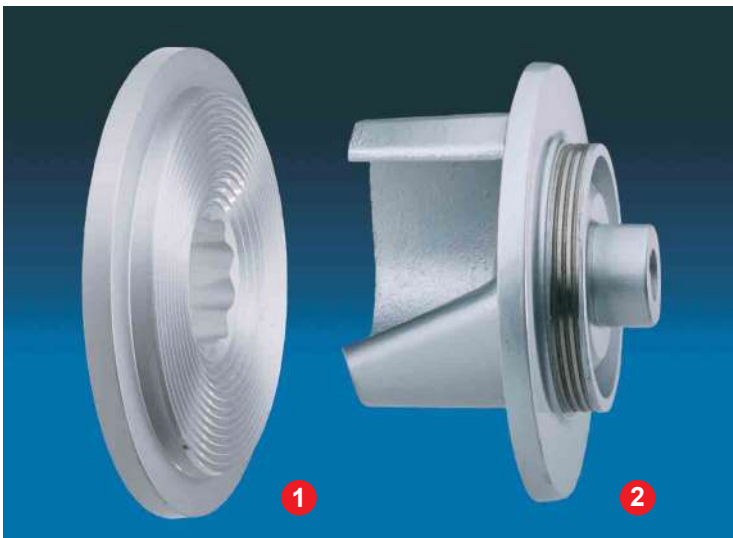

UNIPUMP benefits that ensure operational safety and cost-effectiveness in continuous operation.

1 Non-clogging system

Non-clogging-system for open single and twin vane impeller ensure the greatest possible operational safety. It is guaranteed by a combination of a hard, unprocessed surface of the sealing plate and a specially processed cutting edge on the impeller.

2 Impellers

Open, radial single and twin vane impellers with broad, unrestricted passages.

3 Shaft seal

Single or double-acting mechanical seal with state-of-the-art highly wear-proof materials.

4 By-pass channel

For optimal flushing of mechanical seal by means of the pumped medium.

5 Motor shaft

Rigid motor shafts made from high-alloy stainless steel for minimal deflection.

6 Cost-effectiveness

An extended lifetime is achieved through liberally dimensioned shafts and bearings.

7 Power reserve

Up to 30 % of the motor power is available in the best efficiency range as a power reserve.

8 Flange position

Depending on the size, a number of flange positions are available.

9 Special configurations

Sophisticated solutions to customer-specific problems, type in accordance with military specifications.

TABLE OF CONTENTS

Technical descriptions 4-9
Versions 10
Characteristic curves 11-17
Dimensions 18-19
Technical specifications 20-21
Exploded view 22-23

Use

The close coupled sewage pump UNIPUMP is predominantly used in process engineering plants. It is particularly suitable for pumping contaminated fluids incorporating particle sizes up to 80 mm in diameter.

Their high degree of operational safety means close coupled sewage pumps are also suitable for use in explosion-prone areas and they ensure trouble-free operation of wastewater transport systems and sewage plants. When used on board ships, they thus make a significant contribution to preventing marine pollution.



Construction

High circulation rates are achieved thanks to minimum space requirements and an easy-to-install and readily serviceable compact design. Variable flange positions offer specialist consultants and construction firms optimal design possibilities.

Installation

The pumps are to be used in various installations.



Horizontal installation of the pump



Vertical installation of the pump with the motor at the top

Impellers

Together with the self-actuated non-clogging system, open single-channel and double-channel gears with wide passages guarantees malfunction-free operation even in case of strongly contaminated media.



Open single vane impeller with automatic non-clogging system for feed media with the roughest solid materials and for an operationally reliable feed (practically clog-free).



Open twin vane impeller with automatic non-clogging system for feed media with rough solid materials and for a gentle feed. High running smoothness due to symmetrical form.

Non-clogging system

All pumps are equipped with an automatic non-clogging-system. The installed wearing plates with particularly hard surfaces even abrade the entrained textiles insofar as this function is required for a fault-free flow. At Q_{optimal} this system has approx. 30 % of the rated motor power available as a power reserve.

Range of performance

Speed	Q_{max} [m ³ /h]	H_{max} [m]
1500 rpm (50 Hz)	180	19
1800 rpm (60 Hz)	180	22
3000 rpm (50 Hz)	125	45
3600 rpm (60 Hz)	125	64

Shaft seal

The shaft seal on the pump side is effected in all models via a maintenance-free mechanical seal, which is independent of the direction of rotation and made from wear-resistant silicon carbide (SiC). The required cooling of the sliding surfaces is generated in a targeted manner through the medium via a bypass channel.

In the GD series (double-acting mechanical seal) a mechanical seal made from wear-resistant silicon carbide (SiC) provides the seal on the pump side and a carbon/chromium molybdenum cast mechanical seal provides the seal on the drive side. The intermediate casing is filled with lubricating oil to lubricate and cool the mechanical seals. This oil even enables a short-term dry run. The intermediate casing can be optionally monitored for leaks using a seal electrode.

All motors are equipped with a special seal for splash-proofing on the pump side.

Bearing

The pump and motor have a common shaft, which is supported by a strengthened bearing. From 1.1 kW the 4-pole drives (except for ship type) are in addition equipped with a relubrication unit. In contrast to the standard motor, the pump-side rigid bearing is designed as a reinforced bearing for long life under extreme operating conditions. The high level of running accuracy of the motor shaft is achieved through the high flexural rigidity and short shaft length. This ensures vibration-free running of the mechanical shaft seal.



Noise

The noise emission is determined by complex influencing factors such as size, materials, operating and installation conditions. Noise emission was contained using hydraulic measures and solid construction methods as early as in the development stage. The maximum sound pressure level is generally determined by the drive motors, being caused by air, magnetic and bearing noises. Noise levels are below the permissible limit curves specified for electrical motors as defined by DIN EN 60034-9. Minimum noise emission during operation in the area of Q_{optimal} (best efficiency).

Motor

Various drive options are available.

- High Efficiency Class three-phase motor (IE2)
- Three-phase motor as ship model (IE1)

The standard version is a surface-cooled three-phase motor with squirrel cage corresponding to efficiency class IE2. The compliance with this efficiency class is mandatory since June 2011. Ship's engines are an exception: they are still available in Standard Efficiency Class (IE1). The motor is optionally available with an integrated or external frequency converter. The use of a frequency converter is recommended, but not compulsory.

Motor technology with energy efficiency ^{IE2}

The new High Efficiency motor (IE2) technology offers three decisive advantages:

- More performance due to very high efficiency
- Reduced operating costs due to high energy savings
- Reduced CO₂ emissions due to lower power consumption

Design	IM B5/V1
Motor connection	Manufacturer-specific
Protection type	IP 55
Speed	1500 (1800) rpm 3000 (3600) rpm
Frequency	50 (60) Hz
Connection ≤ 2.2 (2.6) kW	220 Δ / 380 λ (440 λ) V ¹⁾ 230 Δ / 400 λ (460 λ) V
Connection ≥ 3.0 (3.6) kW	380 Δ / 660 λ (440 Δ) V ¹⁾ 400 Δ / 690 λ (460 Δ) V
Insulation class VDE 0530	F

IE2 motors from 5.5 kW at 1500/1800 rpm have a PTC thermistor as standard.

Frequency regulation of pumps is available and depends on the operating conditions:

- from 30 to 50 Hz and from 30 to 60 Hz

General data

- Pump colour RAL 5010 (standard)
- Media temperature range from - 5 to + 60 °C (- 5 to + 40 °C in the explosion protection version)
- Ambient temperature range from - 5 to + 40 °C (or in accordance with the corresponding marine classification)
- Performance verification in conformity with DIN EN ISO 9906, Class 2.
Max. density of the pumped fluid 1050 kg/m³
Max. viscosity of the pumped fluid 1.75 mm²/s

In case of deviating application conditions, the output is corrected in accordance with customer-specific requirements.

Special configurations

- Different voltages and/or frequencies
- Different insulation class
- Elevated ambient temperature
- Elevated protection type
- Enhanced tropical and moisture protection
- Resistant to shock and vibration in conformity with BV 043 and 044
- Non-magnetic and low emission leakage in conformity with BV 3013
- Balancing quality G < 1 in conformity with DIN ISO 1940-1 for low vibration running
- Special materials (high-alloy cast steel, bronze) for parts coming into contact with the product
- Special paint finish
- GD version (see Versions page 10)
- Vertical installation (without feet)
- Design with permanent magnet motor (PM)
- Suction and pressure flange in conformity with national and international standards
- Explosion protection version (ATEX)
- Customer-specific solutions

¹⁾ only for motors as ship model (IE1)

Approval testing

The approval testing can be carried out by all classification societies, the inspection and quality control of the Bundeswehr (German forces) or by the national technical supervisory agencies. For some pumps type approval is available.

Accessories



Frequency converter for direct installation or wall installation



Seal electrode (intermediate casing)

Model designation

Example:

10/HK80-1-155-GD-F-L-EX-W1-S

Motor rating [HP] _____

E.g.: 10 = 10 HP

Speed _____

= 1500 (60 Hz: 1800) rpm

H = 3000 (60 Hz: 3600) rpm

Construction series _____

K = UNIPUMP vane impeller

QSH= UNIPUMP vane impeller

Nominal diameter pressure flange DN [mm] _____

25 = 25 mm

50 = 50 mm

80 = 80 mm

101 = 100 mm

Number of blades _____

Impeller diameter [mm] _____

Sealing _____

= single-acting mechanical seal

GD = double-acting mechanical seal

Installation _____

GF = with casing foot

F = with intermediate casing foot

Flange position (only for F installation) _____

= above (standard)

L = left

VL = centred between above and left

VR = centred between above and right

R = right

Permitted use _____

= standard

EX = Explosion protection (only for GD models)

Materials _____

W0 = mixed materials

W1 = all castings manufactured from EN-GJL-250

W2 = all castings apart from the impeller manufactured from EN-GJL-250, impeller manufactured from CuSn10-C

W3 = all castings manufactured from CuSn10-C

W4 = all castings manufactured from 1.4408

W5 = all castings manufactured from EN-GJS-400-15

W6 = all castings manufactured from 1.4439

Construction _____

= standard

S = special construction

Technical descriptions

Materials ²⁾

¹⁾	Individual components	W1	W2	W3	W4	W5
101	Pump casing	EN-GJL-250 (EN-JL1040)	EN-GJL-250 (EN-JL1040)	CuSn10-C (CC480K)	GX5CrNiMo19-11-2 (1.4408)	EN-GJS-400-15 (EN-JS1030)
113	Intermediate casing	EN-GJL-250 (EN-JL1040)	EN-GJL-250 (EN-JL1040)	CuSn10-C (CC480K)	GX5CrNiMo19-11-2 (1.4408)	EN-GJS-400-15 (EN-JS1030)
162	Suction cover	EN-GJL-250 (EN-JL1040)	EN-GJL-250 (EN-JL1040)	CuSn10-C (CC480K)	GX5CrNiMo19-11-2 (1.4408)	EN-GJS-400-15 (EN-JS1030)
230	Impeller	EN-GJL-250 (EN-JL1040)	CuSn10-C (CC480K)	CuSn10-C (CC480K)	GX5CrNiMo19-11-2 (1.4408)	EN-GJS-400-15 (EN-JS1030)
433/ 433.1	Mechanical seal	SiC/SiC	SiC/SiC	SiC/SiC	SiC/SiC	SiC/SiC
433.2	Mechanical seal	Carbon/chromium molybdenum cast	Carbon/chromium molybdenum cast	Carbon/chromium molybdenum cast	Carbon/chromium molybdenum cast	Carbon/chromium molybdenum cast
502	Casing wear ring	CuSn7Pb15-C (CC496K)	POM	POM	POM	CuSn7Pb15-C (CC496K)
540	Bush	CuSn7Pb15-C (CC496K)	POM	POM	POM	CuSn7Pb15-C (CC496K)
819	Motor shaft	X6CrNiMoTi17-12-2 (1.4571)	X6CrNiMoTi17-12-2 (1.4571)	X6CrNiMoTi17-12-2 (1.4571)	X6CrNiMoTi17-12-2 (1.4571)	X6CrNiMoTi17-12-2 (1.4571)

¹⁾ See exploded view (page 22-23)

²⁾ Other material combinations depending on the operating conditions, e.g. special bronze types and stainless steels.

Versions

Model		Nominal diameter pressure flange DN [mm]	Open single vane impeller (Q)	Open twin vane impeller (Q)	1500/1800 rpm	3000/3600 rpm	Explosion-proof construction	Construction of the double-acting mechanical seal (GD)	Installation with intermediate casing foot (F)	Installation with casing foot (GF)	Flange position V	Flange position L+R	Flange position LV+RV	Grain size [mm]
0.75/K	25-F	25	●	●	●	-	*	*	●	-	●	○	-	15
0.75/K	25-GF	25	●	●	●	-	*	*	-	●	●	-	-	15
1/HK	25-F	25	●	●	-	●	*	*	●	-	●	○	-	15
1/HK	25-GF	25	●	●	-	●	*	*	-	●	●	-	-	15
1.5/HK	25-F	25	-	●	-	●	*	*	●	-	●	○	-	15
1.5/HK	25-GF	25	-	●	-	●	*	*	-	●	●	-	-	15
1/K	50-F	50	●	●	●	-	*	-	●	-	●	○	-	35
3/K	50-F	50	●	●	●	-	○	○	●	-	●	○	-	35
3/HK	50-F	50	●	●	-	●	*	-	●	-	●	○	-	35
4/HK	50-F	50	●	●	-	●	○	○	●	-	●	○	-	35
5.5/HK	50-F	50	-	●	-	●	○	○	●	-	●	○	-	35
3/K	80-F	80	●	-	●	-	*	-	●	-	●	○	○	55
3/K	80-F	80	-	●	●	-	*	-	●	-	●	○	○	ø142=55 ø150=42 ø158, 170, 180=37
4/HK	80-F	80	●	●	-	1 ¹⁾	*	-	●	-	●	○	○	55
5.5/HK	80-F	80	●	●	-	1 ¹⁾	*	-	●	-	●	○	○	55
7.5/HK	80-F	80	●	-	-	●	○	○	●	-	●	○	○	55
7.5/HK	80-F	80	-	1 ¹⁾	-	●	○	○	●	-	●	○	○	ø128, 136=55 ø144=50
10/HK	80-F	80	●	-	-	●	○	○	●	-	●	○	○	55
10/HK	80-F	80	-	●	-	●	○	○	●	-	●	○	○	ø132, 136, 140=55 ø144=50 ø158=37
15/HK	80-F	80	●	-	-	●	*	-	●	-	●	○	○	55
15/HK	80-F	80	-	●	-	●	*	-	●	-	●	○	○	ø144, 148=50 ø150=42 ø154=40 ø162, 167, 170=37
20/HK	80-F	80	●	-	-	●	*	-	●	-	●	○	○	55
20/HK	80-F	80	-	●	-	●	*	-	●	-	●	○	○	ø158, 162, 170, 176, 180=37 ø154=40
4/QSH101-F	100	100	●	1 ²⁾	●	-	○	○	●	-	●	○	○	80
5.5/QSH101-F	100	100	●	●	●	-	○	○	●	-	●	○	○	80
7.5/QSH101-F	100	100	●	●	●	-	*	-	●	-	●	○	○	80
10/QSH101-F	100	100	●	-	●	-	*	-	●	-	●	○	○	80
10/QSH101-F	100	100	-	●	●	-	*	-	●	-	●	○	○	ø210,220,230=70 ø200=80

- Standard
- Option
- cannot be implemented
- * on request

- ¹⁾ only 3000 rpm
- ²⁾ only 1500 rpm

1500 rpm (400 V - 50 Hz)

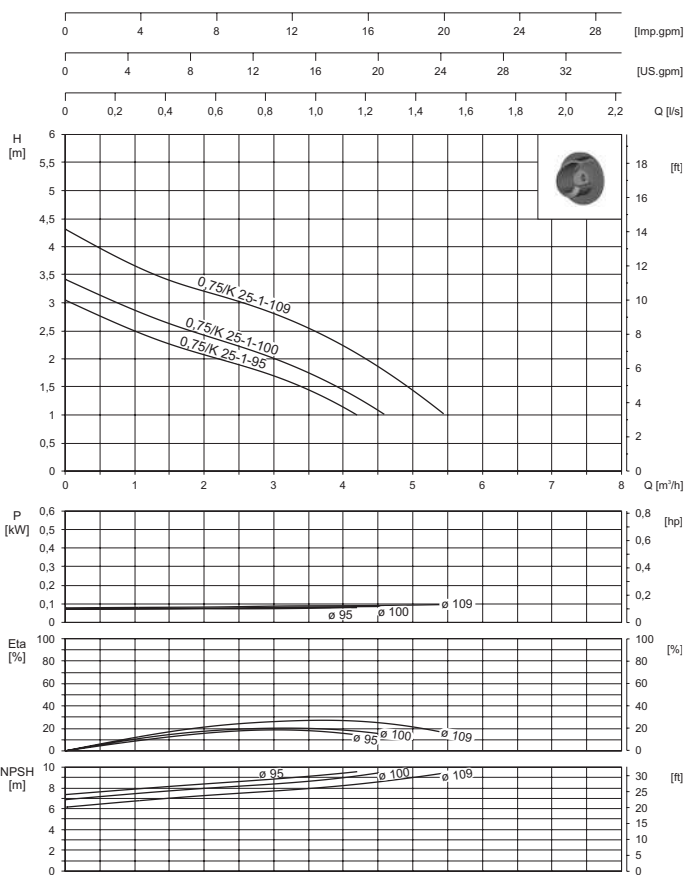

1800 rpm (460 V - 60 Hz)

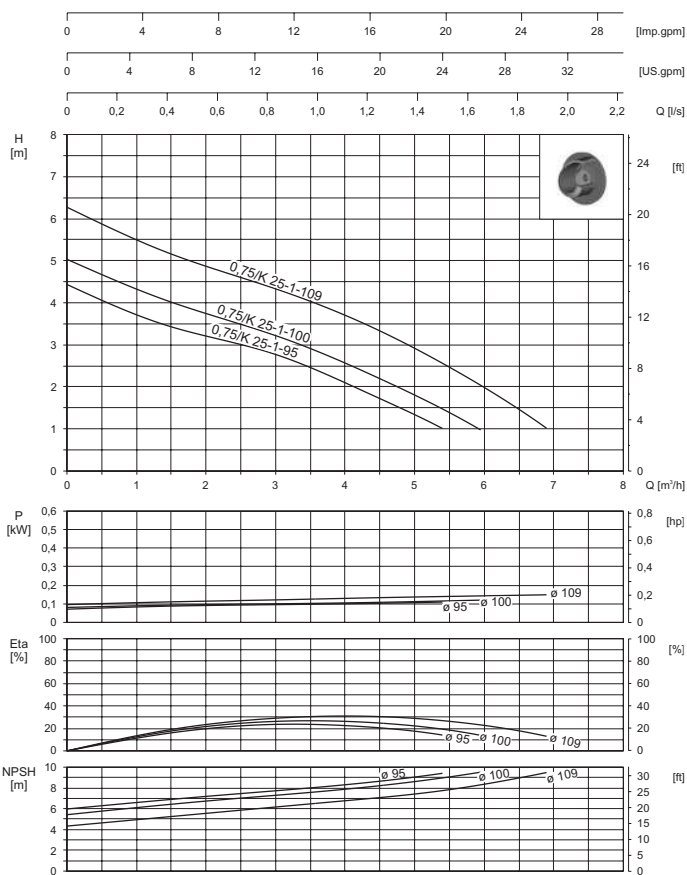

1500 rpm (400 V - 50 Hz)

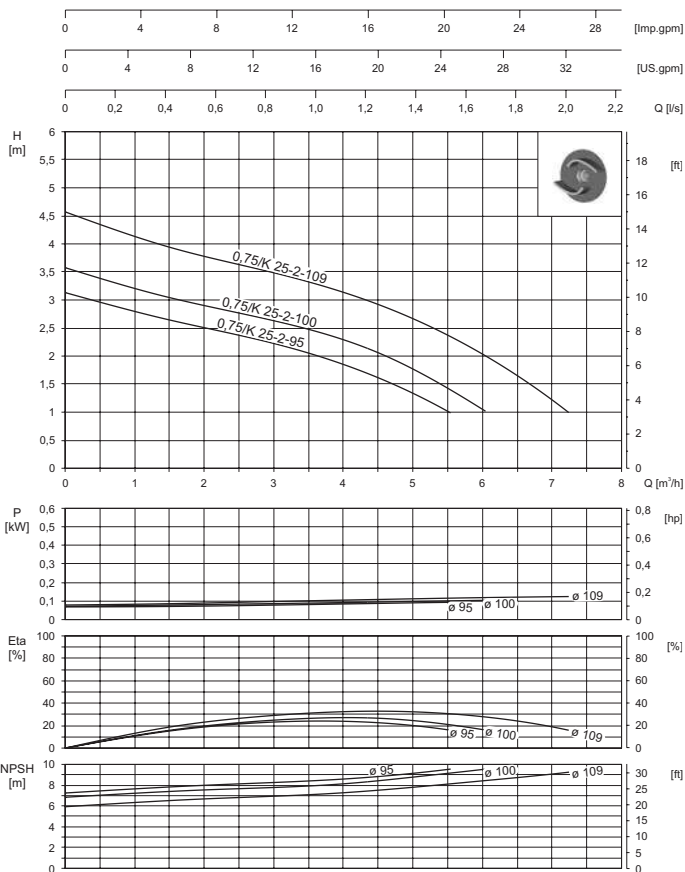

1800 rpm (460 V - 60 Hz)

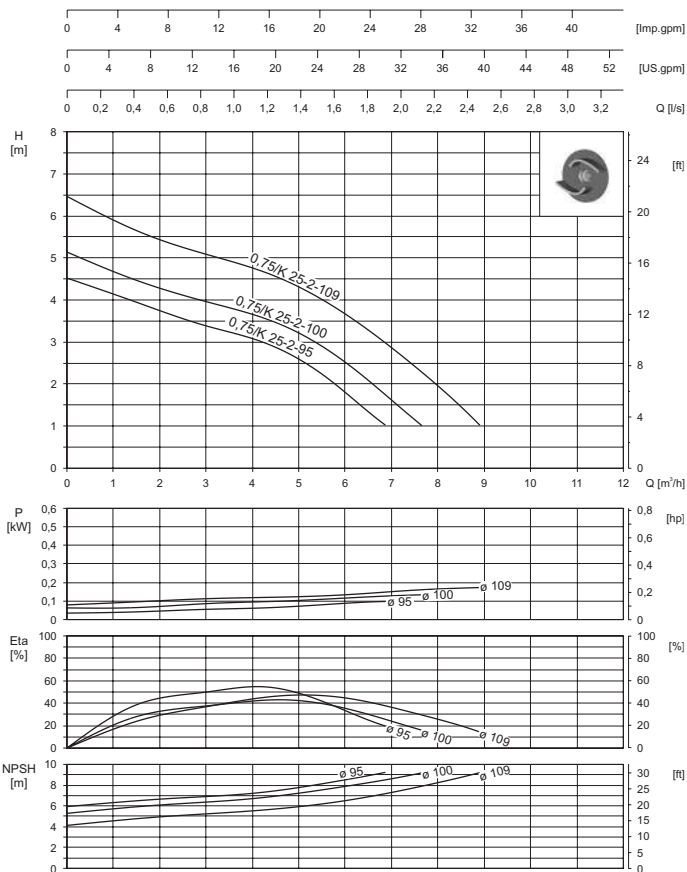

3000 rpm (400 V - 50 Hz)

3600 rpm (460 V - 60 Hz)

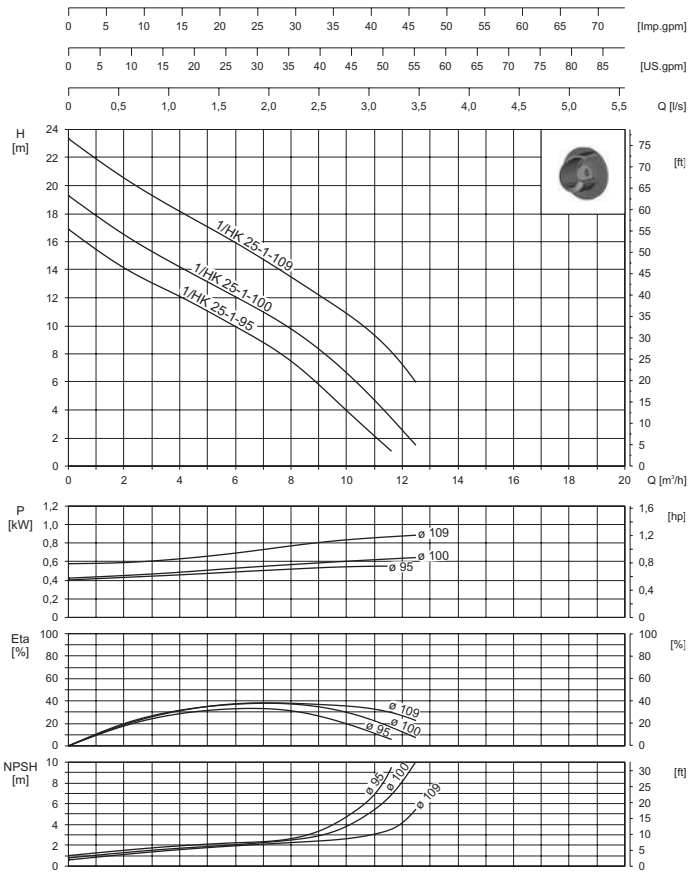
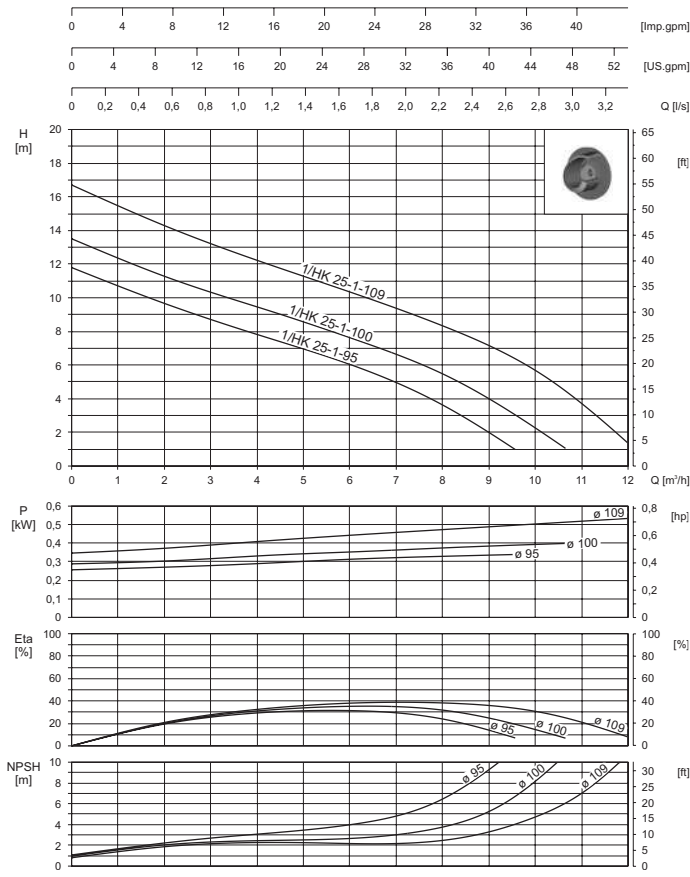

3000 rpm (400 V - 50 Hz)

3600 rpm (460 V - 60 Hz)

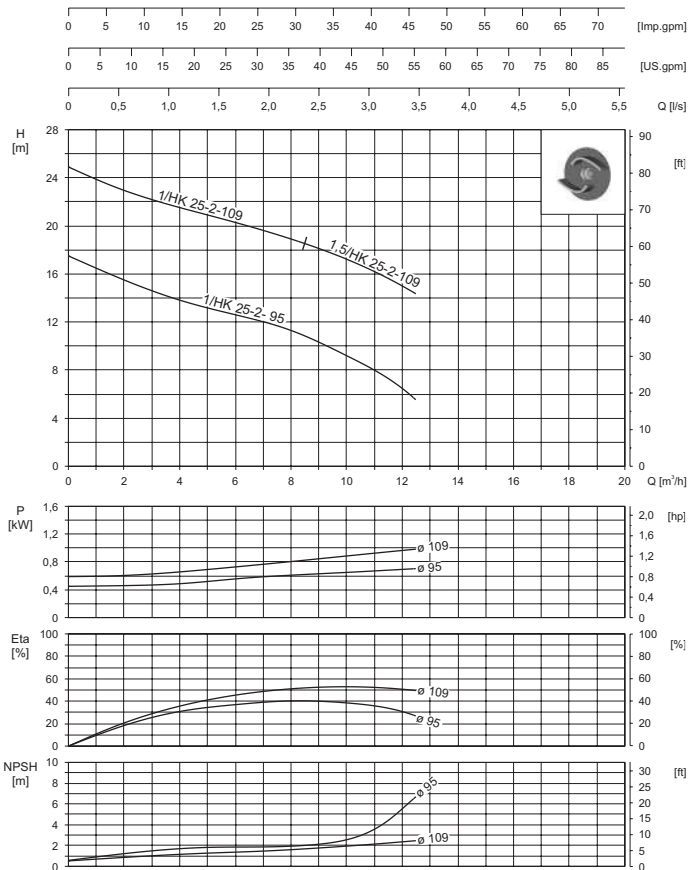
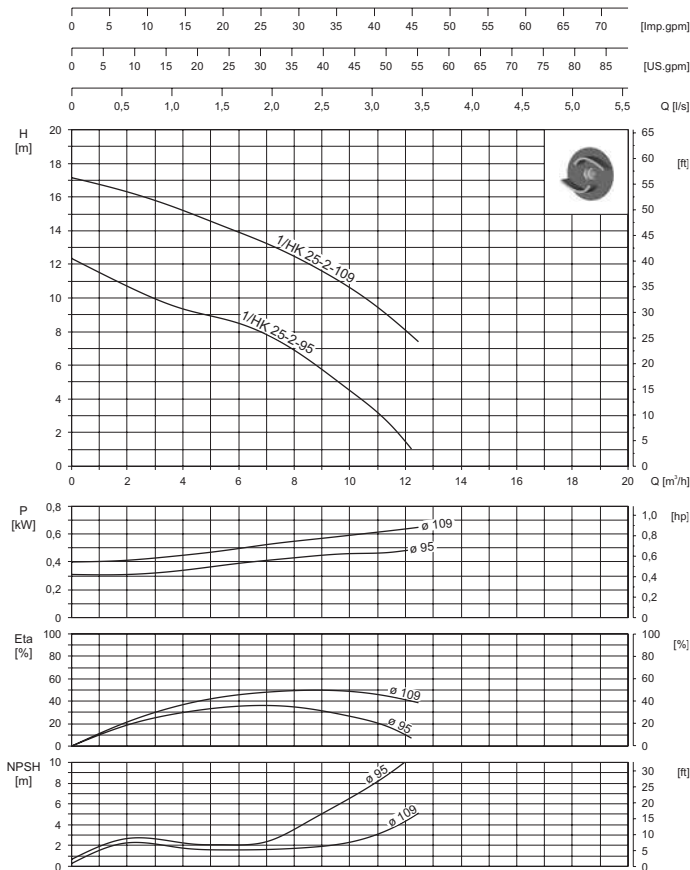

1500 rpm (400 V - 50 Hz)

1800 rpm (460 V - 60 Hz)

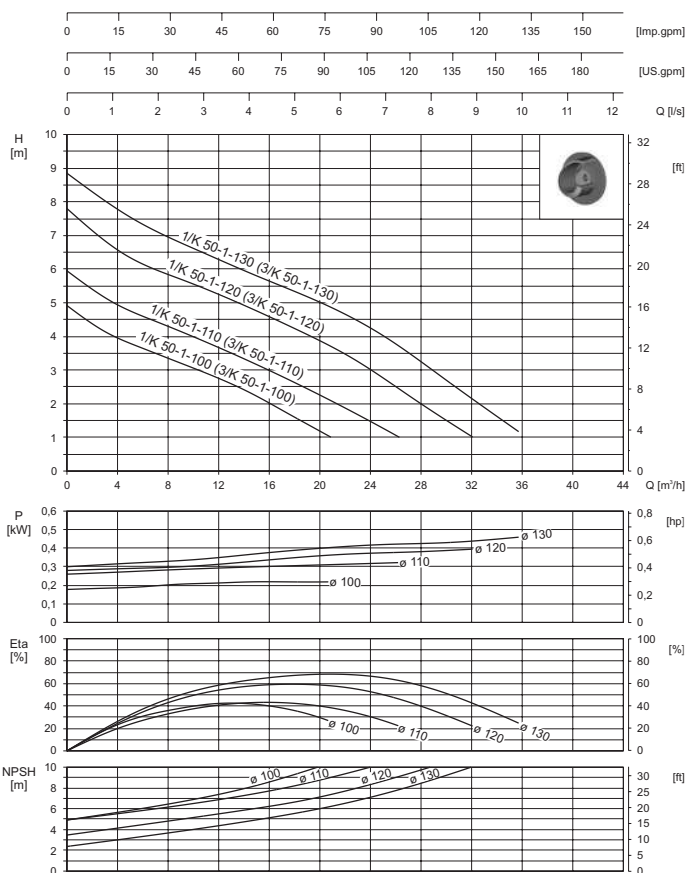
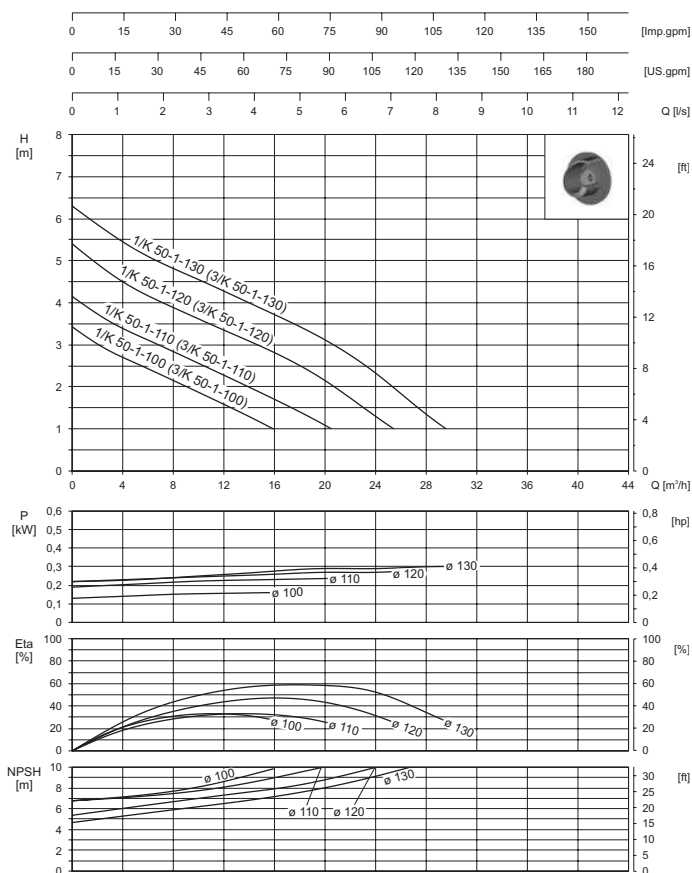

1500 rpm (400 V - 50 Hz)

1800 rpm (460 V - 60 Hz)

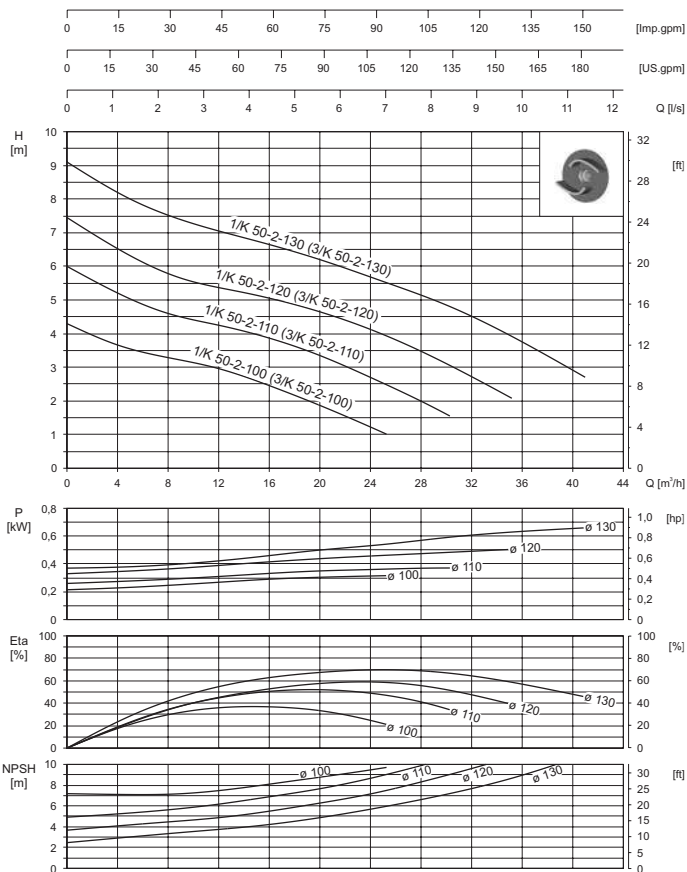
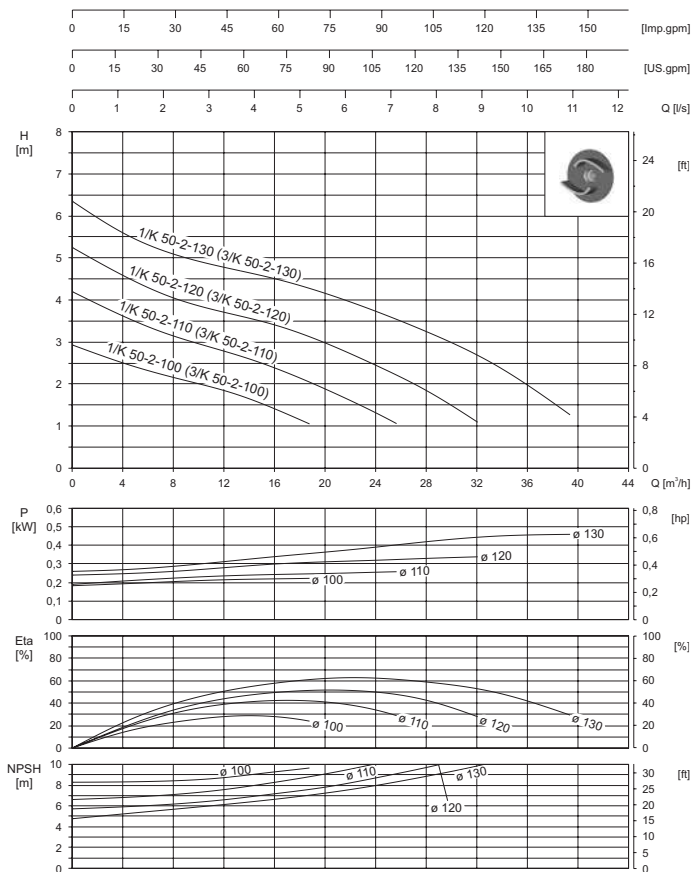

3000 rpm (400 V - 50 Hz)

3600 rpm (460 V - 60 Hz)

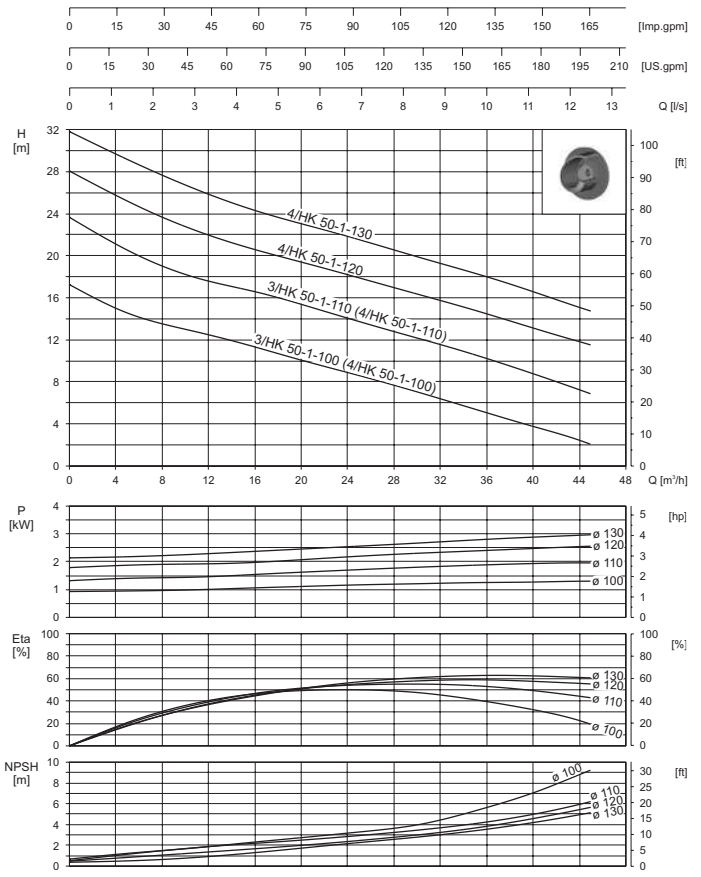
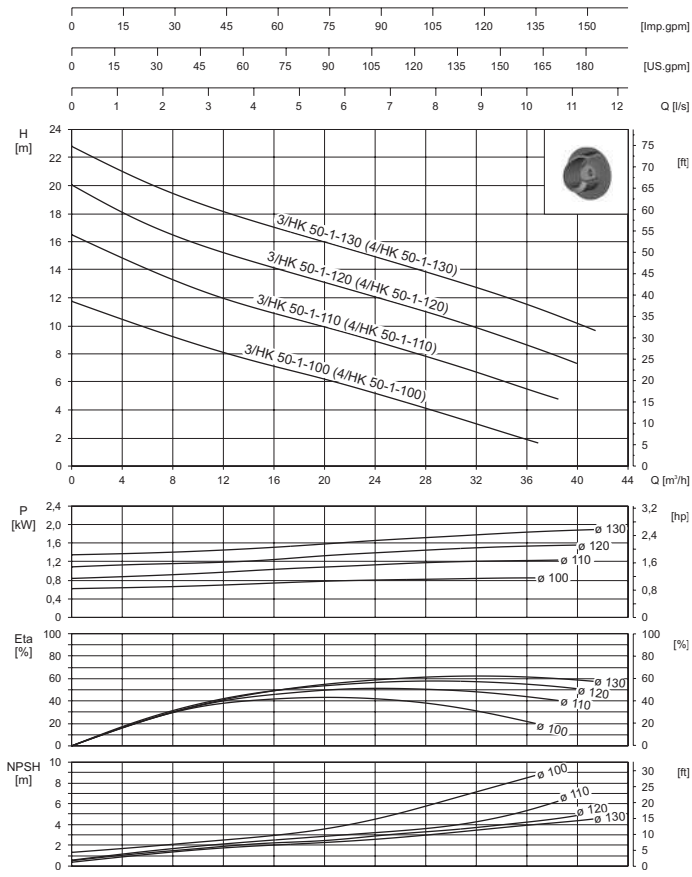

3000 rpm (400 V - 50 Hz)

3600 rpm (460 V - 60 Hz)

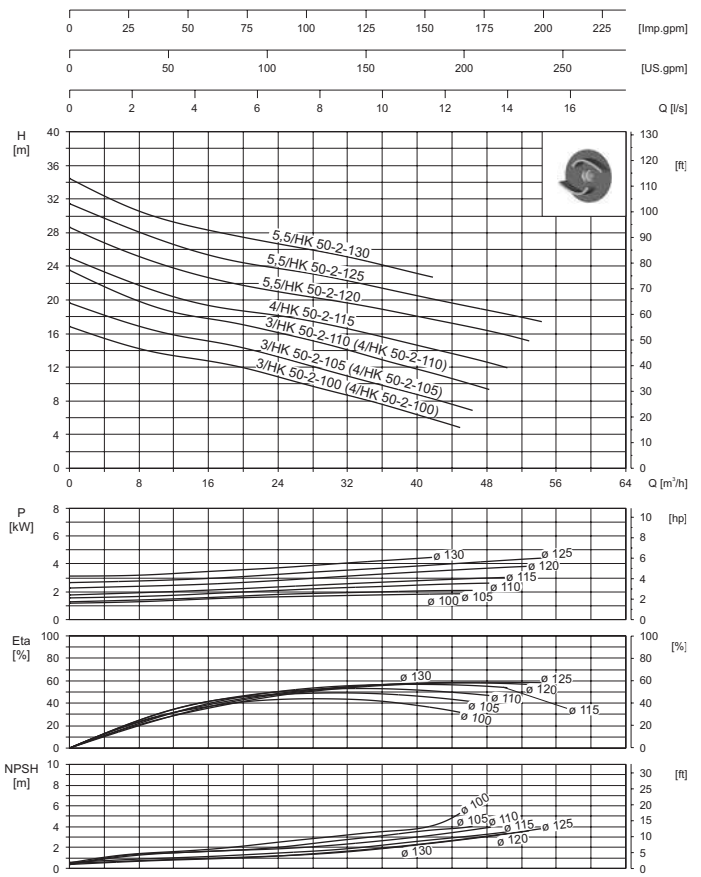
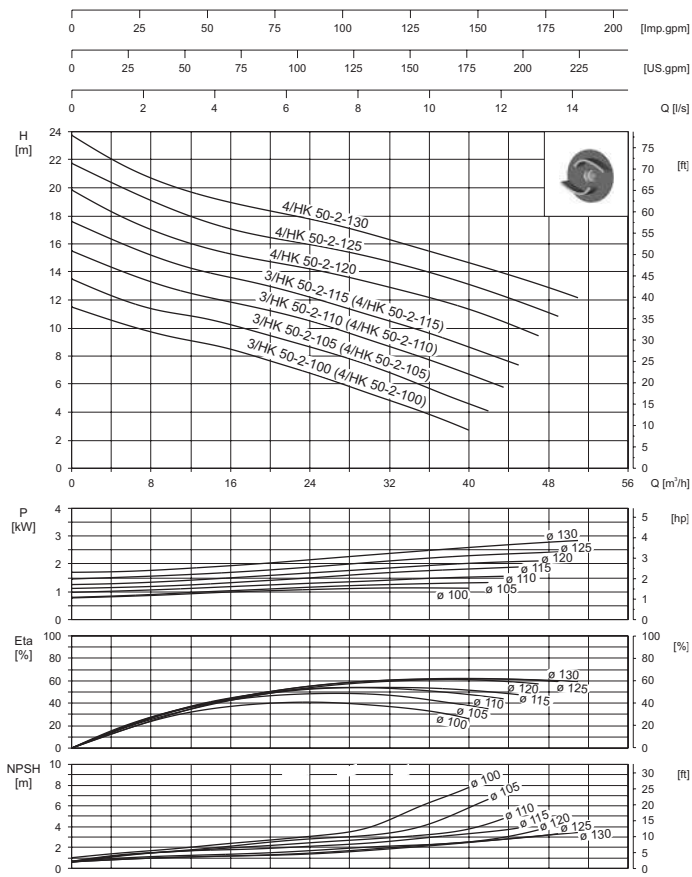

1500 rpm (400 V - 50 Hz)

1800 rpm (460 V - 60 Hz)

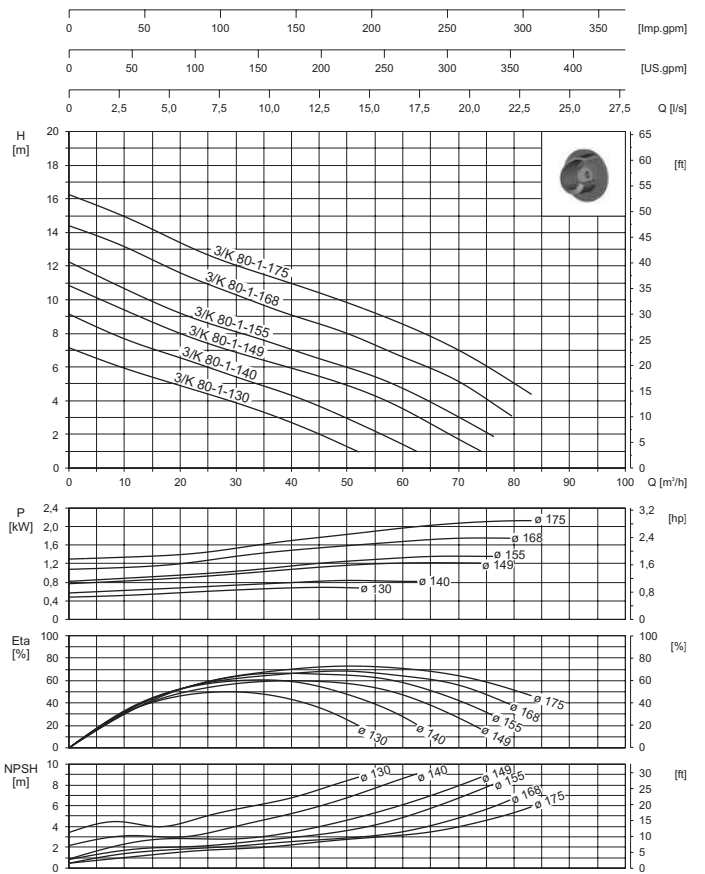
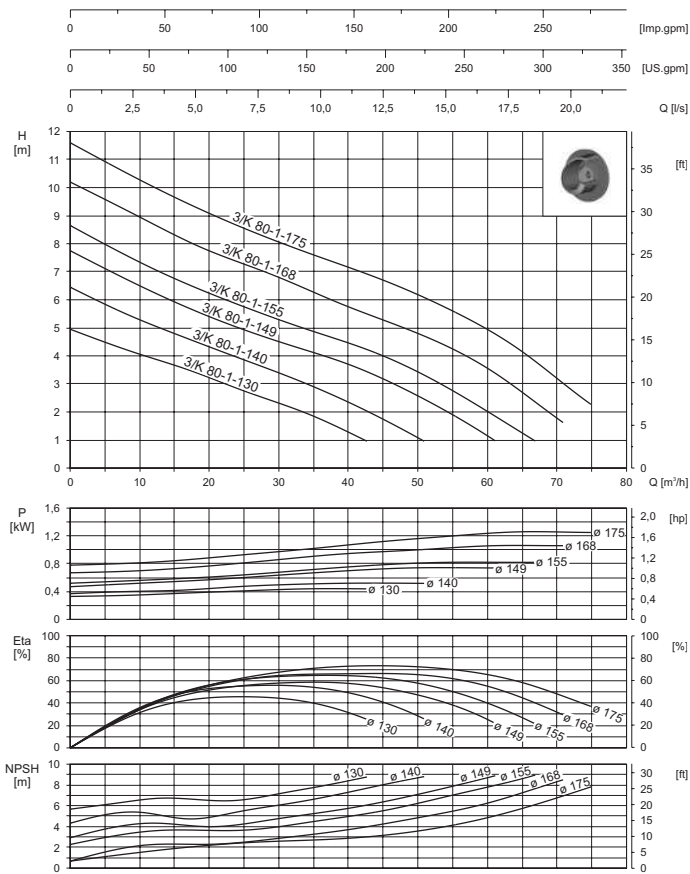

1500 rpm (400 V - 50 Hz)

1800 rpm (460 V - 60 Hz)

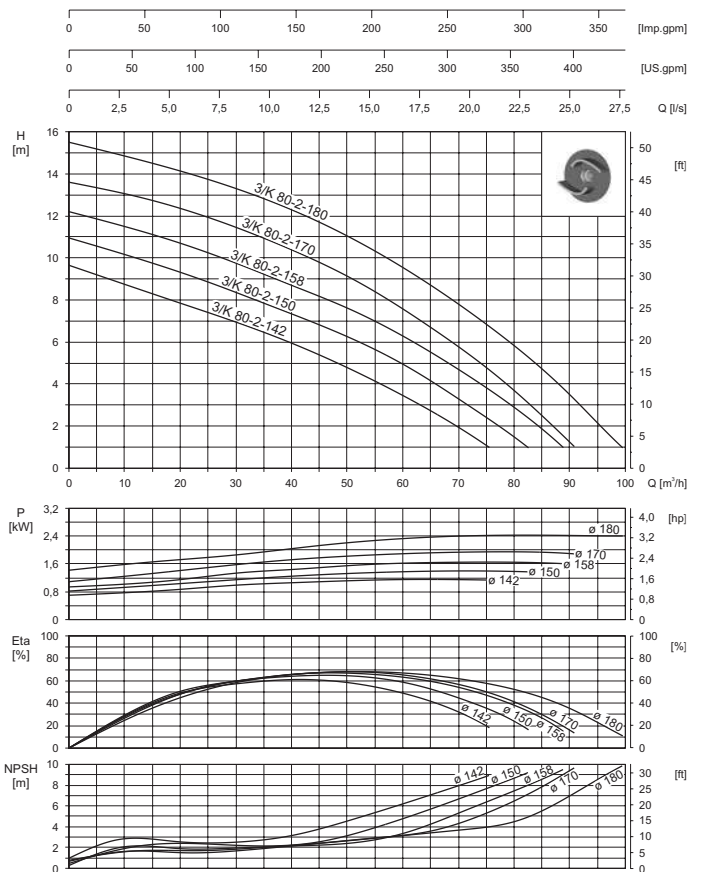
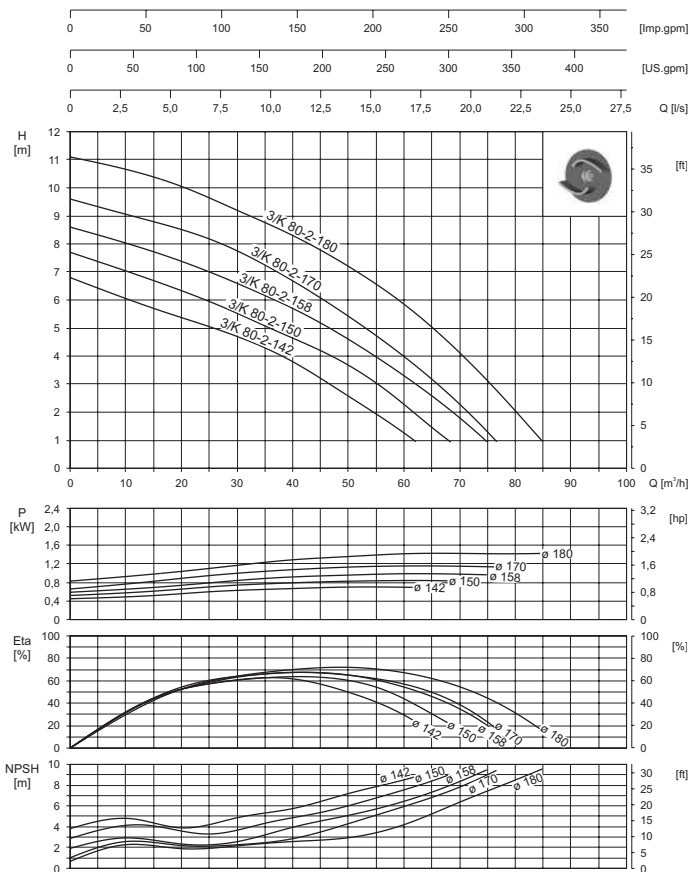

3000 rpm (400 V - 50 Hz)

3600 rpm (460 V - 60 Hz)

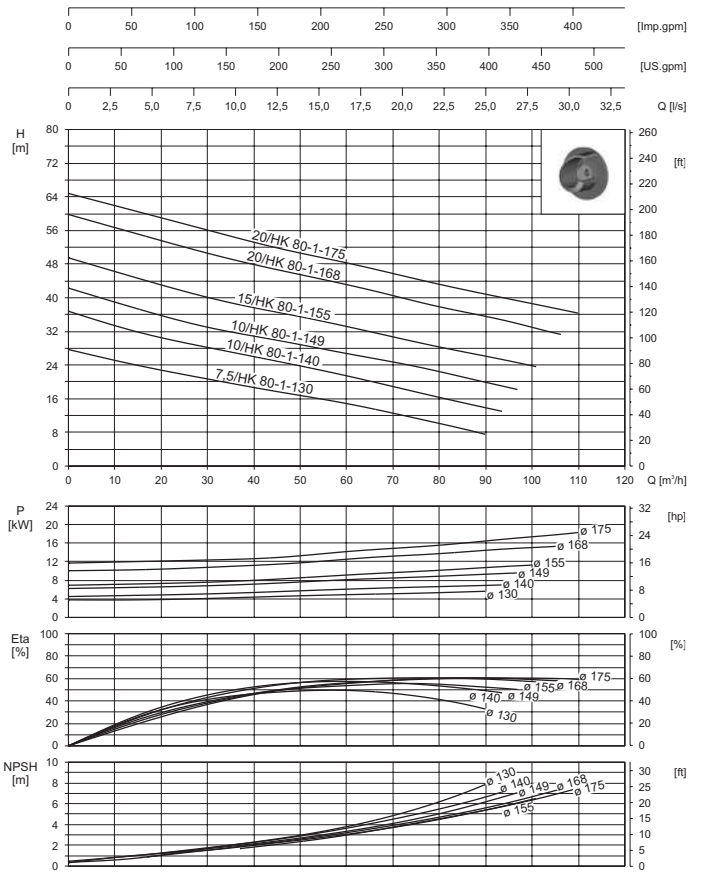
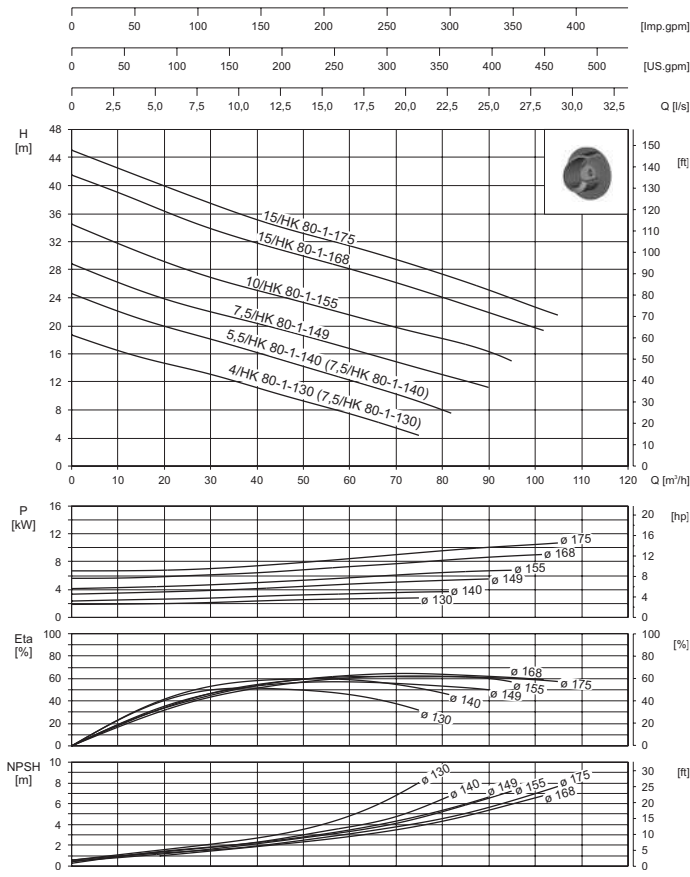

3000 rpm (400 V - 50 Hz)

3600 rpm (460 V - 60 Hz)

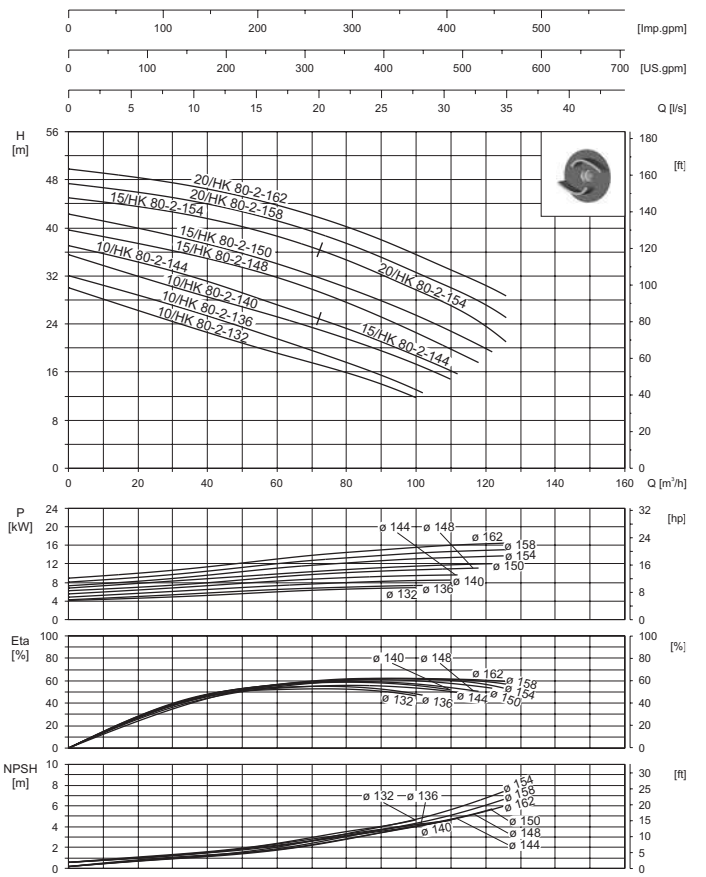
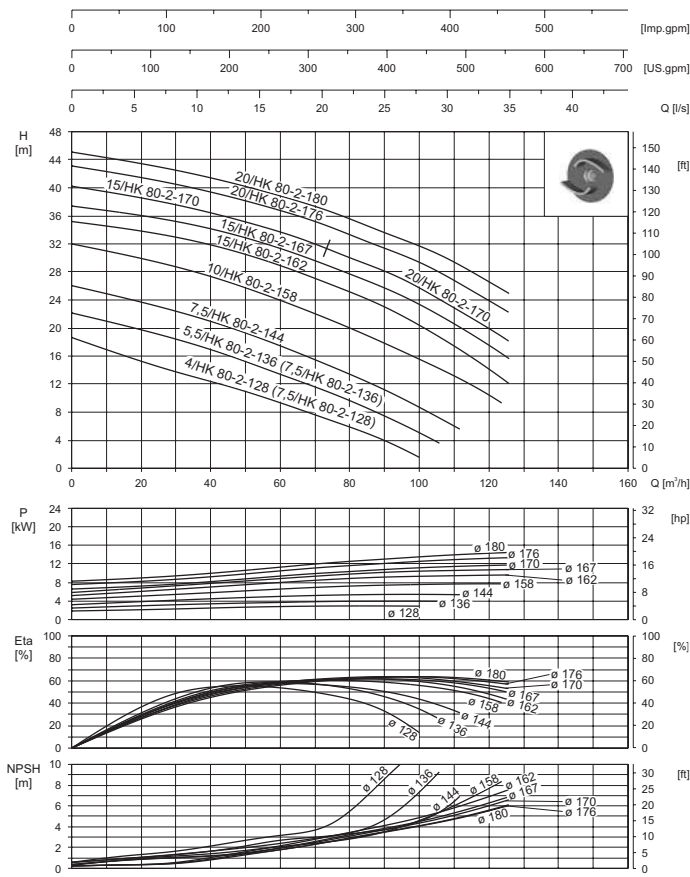

1500 rpm (400 V - 50 Hz)

1800 rpm (460 V - 60 Hz)

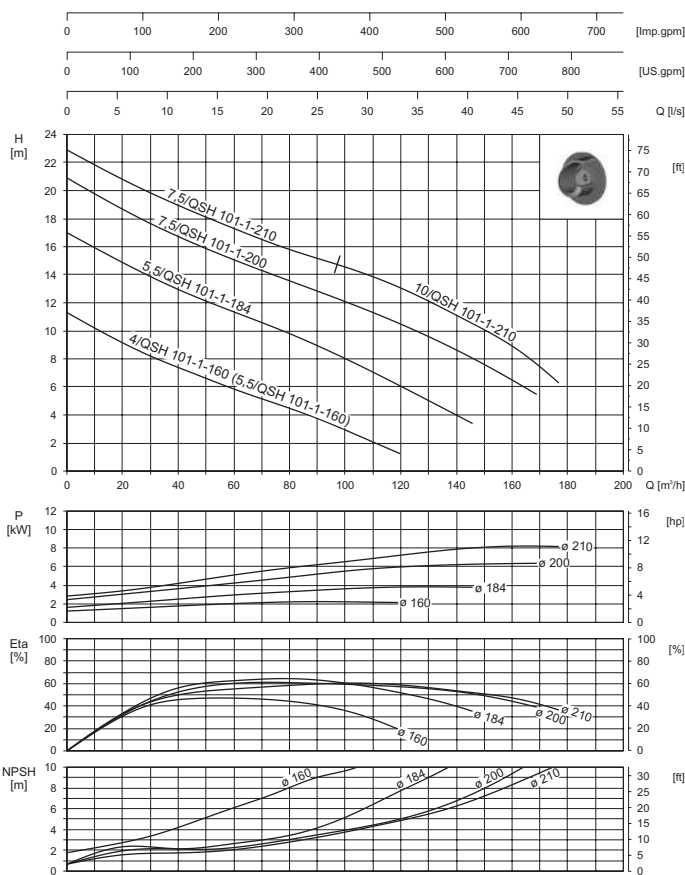
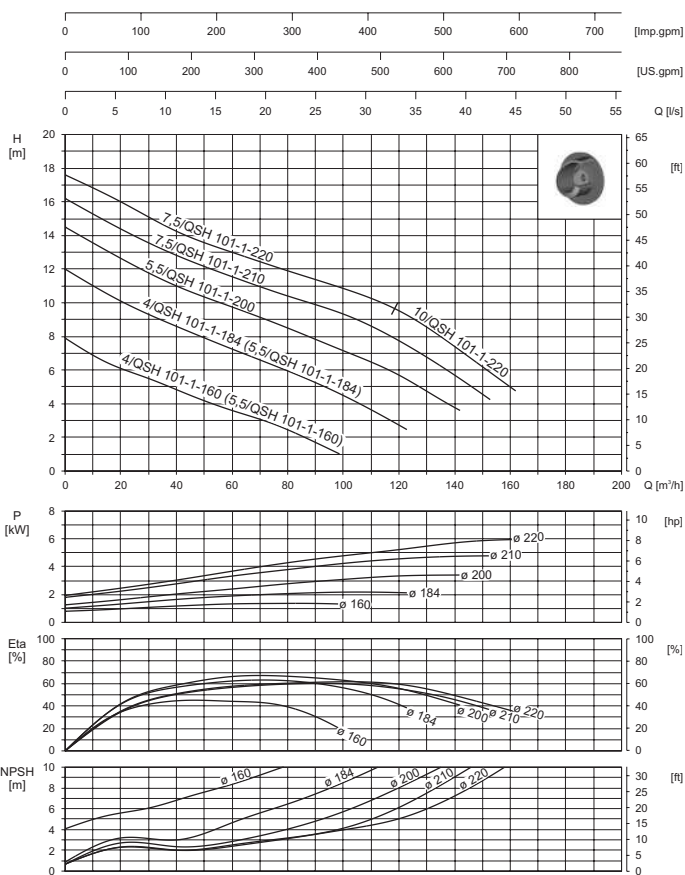

1500 rpm (400 V - 50 Hz)

1800 rpm (460 V - 60 Hz)

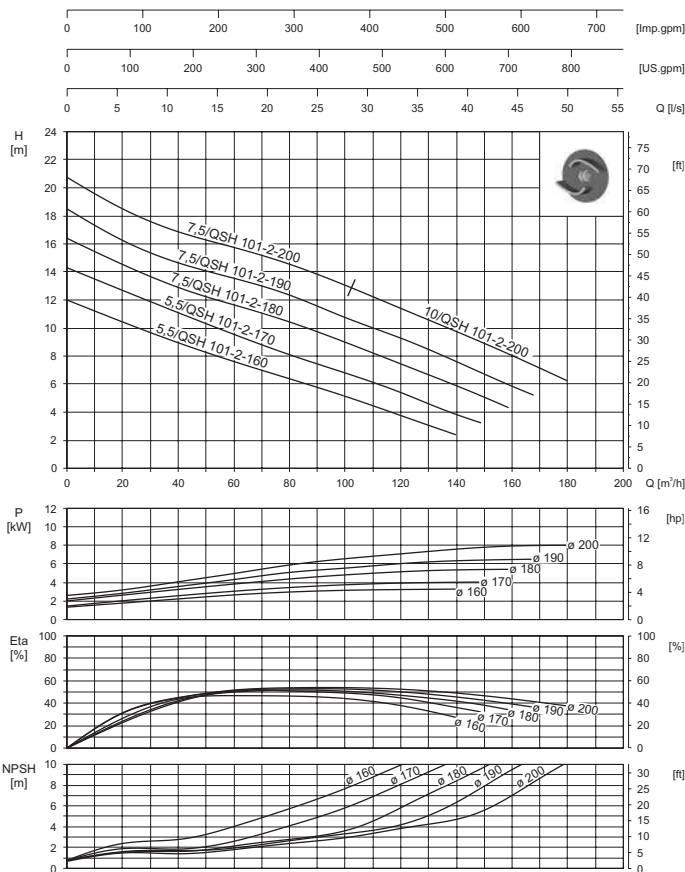
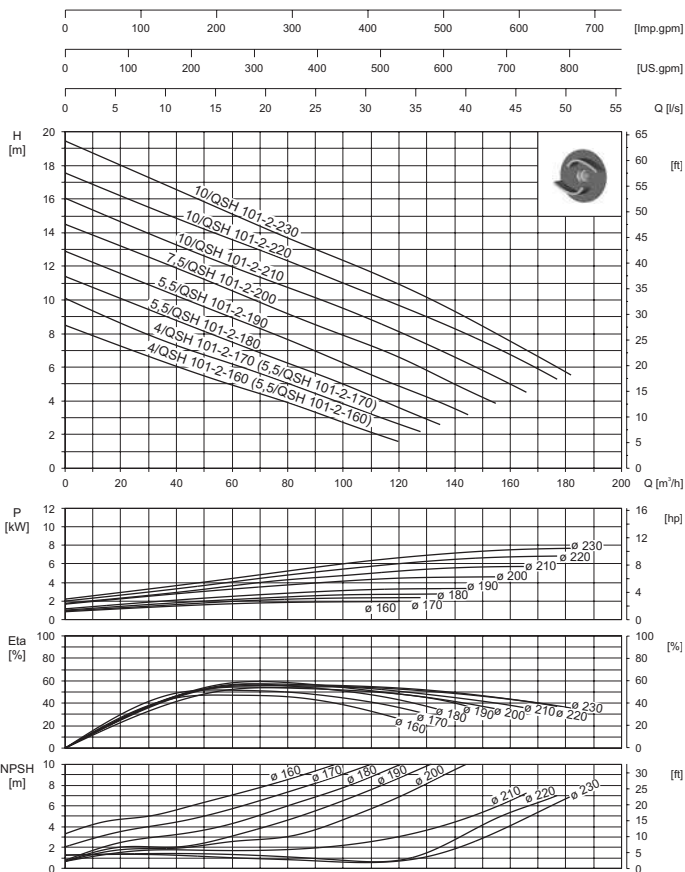

DN 25 - GF

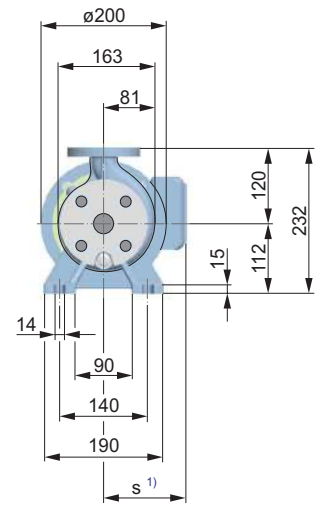
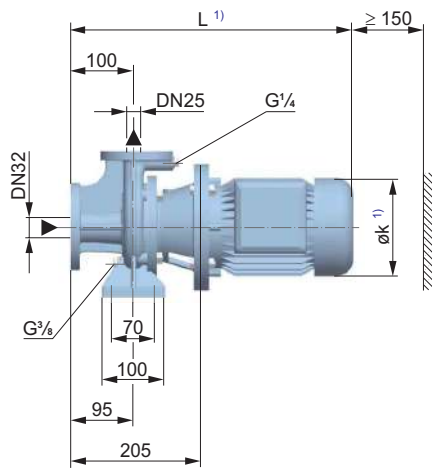

DN 25 - F

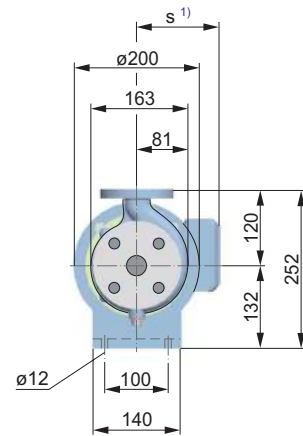
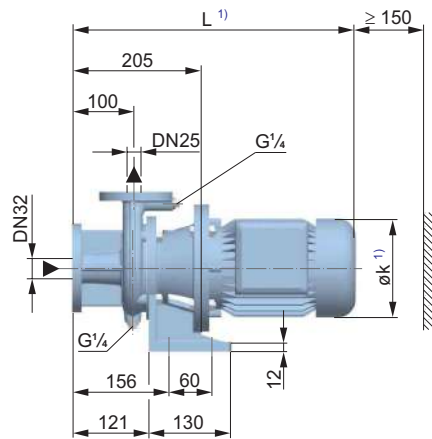

Flange position (DN 25 - F)

Figure L

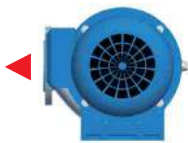

Figure V (standard)



Figure R



Terminal box alignment

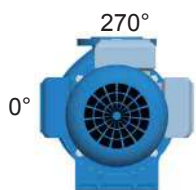

The terminal box alignment in a standard configuration is to the left (0°) when looking at the motor fan.

1) See technical data

Flange connection dimensions according to DIN 2501 PN 10
Customised solutions may differ from these standard data.

DN 50 - F/ DN 80 - F/ DN 100 - F

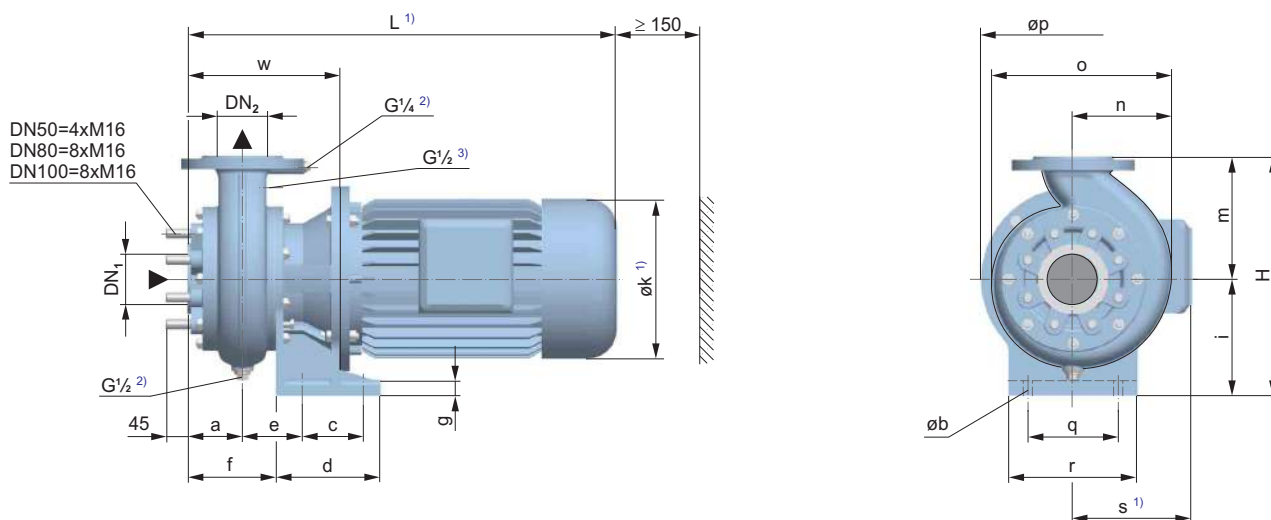

Model	DN _{v/2}	H	a	øb	c	d	e	f	g	i	m	n	o	øp	q	r	w
1/K 50 - F	50	292	70	12	60	130	84	120	12	132	160	117	213	200	100	140	199
3/K 50 - F	50	320	70	15	80	150	73	108	14	160	160	117	213	250	130	180	210
3/HK 50 - F	50	292	70	12	60	130	84	120	12	132	160	117	213	200	100	140	199
4/HK 50 - F	50	320	70	15	80	150	73	108	14	160	160	117	213	250	130	180	210
5.5/HK 50 - F	50	320	70	15	80	150	73	108	14	160	160	117	213	250	130	180	210
3/K 80 - F	80	390	91	15	100	170	90	146	14	190	200	160	290	250	160	210	242
4/HK 80 - F	80	390	91	15	100	170	90	146	14	190	200	160	290	250	160	210	242
5.5/HK 80 - F	80	390	91	15	100	170	90	146	14	190	200	160	290	250	160	210	242
7.5/HK 80 - F	80	390	91	15	100	170	95	146	25	190	200	160	290	300	160	210	252
10/HK 80 - F	80	390	91	15	100	170	95	146	25	190	200	160	290	300	160	210	252
15/HK 80 - F	80	390	91	15	100	170	95	146	25	190	200	160	290	300	160	210	257
20/HK 80 - F	80	390	91	15	100	170	95	146	25	190	200	160	290	300	160	210	257
4/QSH101 - F	100	415	91	15	90	160	95	151	25	200	215	158	310	295	150	200	259
5.5/QSH101 - F	100	415	91	15	90	160	95	151	25	200	215	158	310	295	150	200	259
7.5/QSH101 - F	100	415	91	15	90	160	95	151	25	200	215	158	310	295	150	200	259
10/QSH101 - F	100	415	91	15	90	160	95	151	25	200	215	158	310	295	150	200	259

Flange position

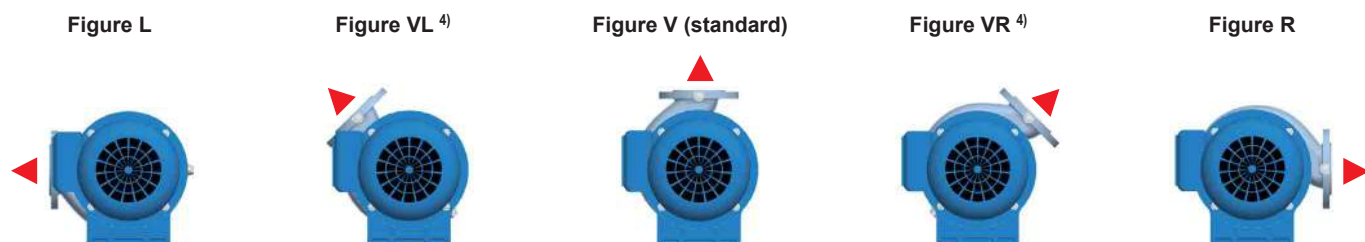

Terminal box alignment



The terminal box alignment in a standard configuration is to the left (0°) when looking at the motor fan.

- 1) See technical data
- 2) only DN 50 and DN 80
- 3) only DN 100
- 4) only DN 80 and DN 100

Flange connection dimensions according to DIN 2501 PN 10
Customised solutions may differ from these standard data.

Ship IE1 - 50 Hz: 1500 rpm (380 V)

Model	P ₂ [kW]	I [A]	I _A /I _N	dB(A)	m[kg]	L	øk	s
0.75/K25	0.55	1.6	4.2	50	30	445	156	135
1/K50	0.75	2.2	4.4	50	38	440	156	135
3/K50	2.2	5.1	5.6	59	55	525	198	157
3/K80	2.2	5.1	5.6	59	78	555	198	157
4/QSH101	3.0	6.8	6.1	59	94	605	198	157
5.5/QSH101	4.0	9.0	6.7	59	100	635	220	169
7.5/QSH101	5.5	11.5	5.9	63	128	690	260	195
10/QSH101	7.5	15.5	6.0	63	147	705	260	199

Ship IE1 - 60 Hz: 1800 rpm (440 V)

Model	P ₂ [kW]	I [A]	I _A /I _N	dB(A)	m[kg]	L	øk	s
0.75/K25	0.66	1.5	4.5	54	30	445	156	135
1/K50	0.9	2.1	4.8	54	38	440	156	135
3/K50	2.6	5.2	5.8	63	55	525	198	157
3/K80	2.6	5.2	5.8	63	78	555	198	157
4/QSH101	3.6	7.0	6.2	63	93	605	198	157
5.5/QSH101	4.8	9.0	6.6	63	100	635	220	169
7.5/QSH101	6.6	12.0	5.0	67	128	690	260	195
10/QSH101	9.0	16.0	5.6	67	146	705	260	199

Ship IE1 - 50 Hz: 1500 rpm (400 V)

Model	P ₂ [kW]	I [A]	I _A /I _N	dB(A)	m[kg]	L	øk	s
0.75/K25	0.55	1.7	4.8	50	30	445	156	135
1/K50	0.75	2.1	4.8	50	38	440	156	135
3/K50	2.2	5.3	5.9	59	55	525	198	157
3/K80	2.2	5.3	5.9	59	78	555	198	157
4/QSH101	3.0	7.0	6.2	59	94	605	198	157
5.5/QSH101	4.0	9.0	6.8	59	100	635	220	169
7.5/QSH101	5.5	11.4	6.6	63	128	690	260	195
10/QSH101	7.5	15.4	6.8	63	147	705	260	199

Ship IE1 - 60 Hz: 1800 rpm (460 V)

Model	P ₂ [kW]	I [A]	I _A /I _N	dB(A)	m[kg]	L	øk	s
0.75/K25	0.66	1.7	4.6	54	30	445	156	135
1/K50	0.9	2.2	4.8	54	38	440	156	135
3/K50	2.6	5.5	6.1	63	55	525	198	157
3/K80	2.6	5.5	6.1	63	78	555	198	157
4/QSH101	3.6	7.2	6.6	63	93	605	198	157
5.5/QSH101	4.8	9.1	7.0	63	100	635	220	169
7.5/QSH101	6.6	11.9	6.3	67	128	690	260	195
10/QSH101	9.0	16.1	6.5	67	146	705	260	199

Ship IE1 - 50 Hz: 3000 rpm (380 V)

Model	P ₂ [kW]	I [A]	I _A /I _N	dB(A)	m[kg]	L	øk	s
1/HK25	0.75	1.7	5.6	63	30	445	156	135
3/HK50	2.2	4.7	7.0	67	45	500	176	148
4/HK50	3.0	6.4	6.4	72	56	525	198	157
4/HK80	3.0	6.4	6.4	72	79	555	198	157
5.5/HK80	4.0	8.2	6.4	74	88	620	220	169
7.5/HK80	5.5	11.2	7.0	74	120	660	260	195
10/HK80	7.5	15.0	5.8	74	122	700	260	195
15/HK80	11.0	21.0	7.0	75	168	770	315	253
20/HK80	15.0	28.5	7.1	75	178	735	315	253

Ship IE1 - 60 Hz: 3600 rpm (440 V)

Model	P ₂ [kW]	I [A]	I _A /I _N	dB(A)	m[kg]	L	øk	s
1/HK25	0.9	1.8	5.5	67	30	445	156	135
1.5/HK25	1.3	2.5	5.8	67	35	445	156	135
3/HK50	2.6	4.8	7.3	71	45	500	176	148
4/HK50	3.6	6.3	6.3	76	56	525	198	157
5.5/HK50	4.8	8.4	6.5	78	65	590	220	169
7.5/HK80	6.6	11.5	8.0	78	118	660	260	195
10/HK80	9.0	15.8	5.6	78	122	700	260	195
15/HK80	13.2	22.0	6.4	79	168	770	315	253
20/HK80	18.0	29.5	6.6	79	178	735	315	253

Ship IE1 - 50 Hz: 3000 rpm (400 V)

Model	P ₂ [kW]	I [A]	I _A /I _N	dB(A)	m[kg]	L	øk	s
1/HK25	0.75	1.9	5.6	63	30	445	156	135
3/HK50	2.2	4.6	7.5	67	45	500	176	148
4/HK50	3.0	6.5	6.5	72	56	525	198	157
4/HK80	3.0	6.5	6.5	72	79	555	198	157
5.5/HK80	4.0	8.3	8.4	74	88	620	220	169
7.5/HK80	5.5	11.0	6.3	74	120	660	260	195
10/HK80	7.5	15.3	6.5	74	122	700	260	195
15/HK80	11.0	20.5	7.0	75	168	770	315	253
20/HK80	15.0	27.0	7.1	75	178	735	315	253

Ship IE1 - 60 Hz: 3600 rpm (460 V)

Model	P ₂ [kW]	I [A]	I _A /I _N	dB(A)	m[kg]	L	øk	s
1/HK25	0.9	1.8	6.1	67	30	445	156	135
1.5/HK25	1.3	2.8	6.3	67	35	445	156	135
3/HK50	2.6	4.8	6.6	71	45	500	176	148
4/HK50	3.6	6.7	6.2	76	56	525	198	157
5.5/HK50	4.8	8.7	8.1	78	65	590	220	169
7.5/HK80	6.6	11.5	6.0	78	118	660	260	195
10/HK80	9.0	15.1	6.3	78	122	700	260	195
15/HK80	13.2	21.4	6.7	79	168	770	315	253
20/HK80	18.0	28.2	6.8	79	178	735	315	253

Values for explosion protection versions on request

Customised solutions may differ from these standard data.

IE2 - 50 Hz: 1500 rpm (400 V)

Model	P ₂ [kW]	I [A]	I _A /I _N	dB(A)	m [kg]	L	øk	s
0.75/K25	0.55	1.7	4.8	50	30	445	156	135
1/K50	0.75	2.1	4.8	50	38	440	156	135
3/K50	2.2	5.3	5.9	59	55	525	198	157
3/K80	2.2	5.3	5.9	59	78	555	198	157
4/QSH101	3.0	7.0	6.2	59	94	605	198	157
5.5/QSH101	4.0	9.0	6.8	59	100	635	220	169
7.5/QSH101	5.5	11.4	6.6	63	128	690	260	195
10/QSH101	7.5	15.4	6.8	63	147	705	260	199

IE2 - 60 Hz: 1800 rpm (460 V)

Model	P ₂ [kW]	I [A]	I _A /I _N	dB(A)	m [kg]	L	øk	s
0.75/K25	0.66	1.7	4.6	54	30	445	156	135
1/K50	0.9	2.2	4.8	54	38	440	156	135
3/K50	2.6	5.5	6.1	63	55	525	198	157
3/K80	2.6	5.5	6.1	63	78	555	198	157
4/QSH101	3.6	7.2	6.6	63	93	605	198	157
5.5/QSH101	4.8	9.1	7.0	63	100	635	220	169
7.5/QSH101	6.6	11.9	6.3	67	128	690	260	195
10/QSH101	9.0	16.1	6.5	67	146	705	260	199

IE2 - 50 Hz: 3000 rpm (400 V)

Model	P ₂ [kW]	I [A]	I _A /I _N	dB(A)	m [kg]	L	øk	s
1/HK25	0.75	1.9	5.6	63	30	445	156	135
3/HK50	2.2	4.6	7.5	67	45	500	176	148
4/HK50	3.0	6.5	6.5	72	56	525	198	157
4/HK80	3.0	6.5	6.5	72	79	555	198	157
5.5/HK80	4.0	8.3	8.4	74	88	620	220	169
7.5/HK80	5.5	11.0	6.3	74	120	660	260	195
10/HK80	7.5	15.3	6.5	74	122	700	260	195
15/HK80	11.0	20.5	7.0	75	168	770	315	253
20/HK80	15.0	27.0	7.1	75	178	735	315	253

IE2 - 60 Hz: 3600 rpm (460 V)

Model	P ₂ [kW]	I [A]	I _A /I _N	dB(A)	m [kg]	L	øk	s
1/HK25	0.9	1.8	6.1	67	30	445	156	135
1.5/HK25	1.3	2.8	6.3	67	35	445	156	135
3/HK50	2.6	4.8	6.6	71	45	500	176	148
4/HK50	3.6	6.7	6.2	76	56	525	198	157
5.5/HK50	4.8	8.7	8.1	78	65	590	220	169
7.5/HK80	6.6	11.5	6.0	78	118	660	260	195
10/HK80	9.0	15.1	6.3	78	122	700	260	195
15/HK80	13.2	21.4	6.7	79	168	770	315	253
20/HK80	18.0	28.2	6.8	79	178	735	315	253

Legend:

- P₂: Rated power
- I: Rated current
- I_A/I_N: Locked-rotor current related to rated current
- dB(A): Sound pressure level of the complete pump. Tolerance +/- 3 dB(A)
- m: Total weight of the pump (for standard installation)
- L: Total length of the pump [mm]
- øk: Motor diameter [mm]
- s: maximum terminal box dimension

Values for explosion protection versions on request

Customised solutions may differ from these standard data.

Exploded view

DN 25

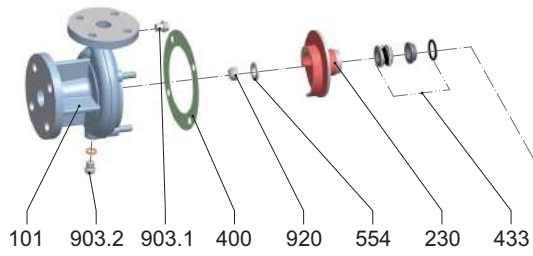

DN 50

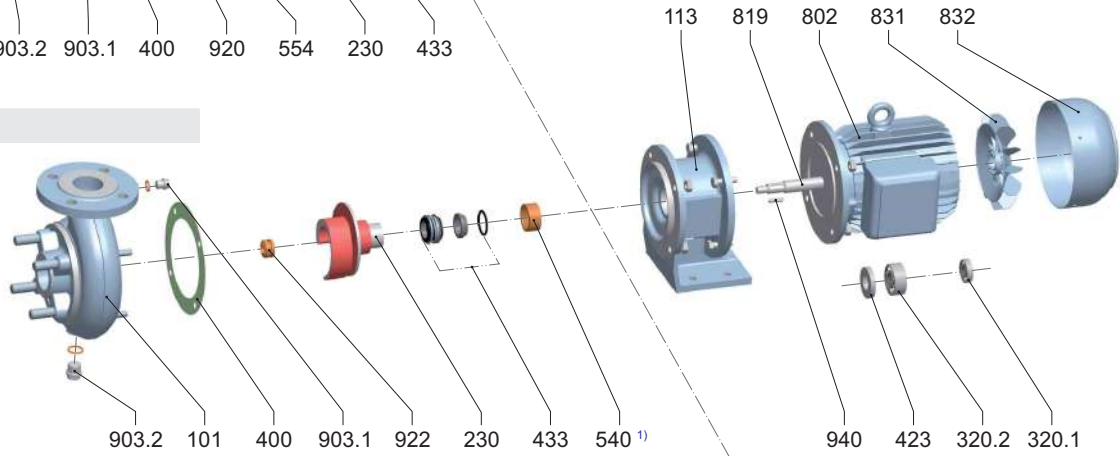

DN 80 / DN 100

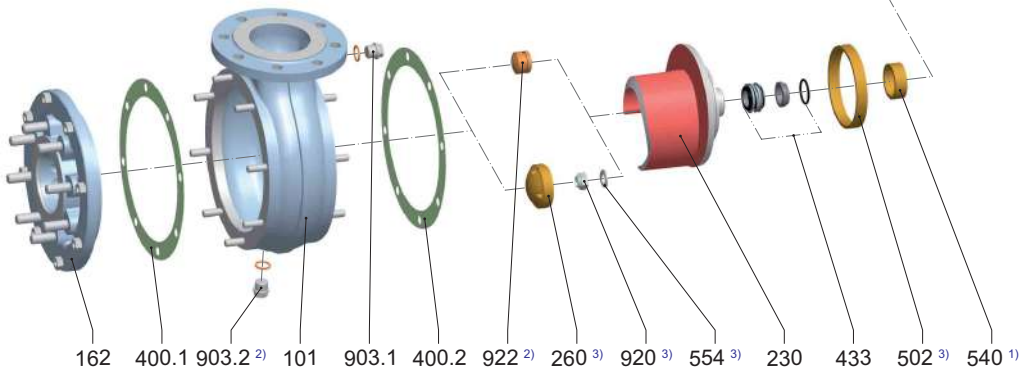

Design of the double-acting mechanical seal (GD)

DN 50 / DN 80

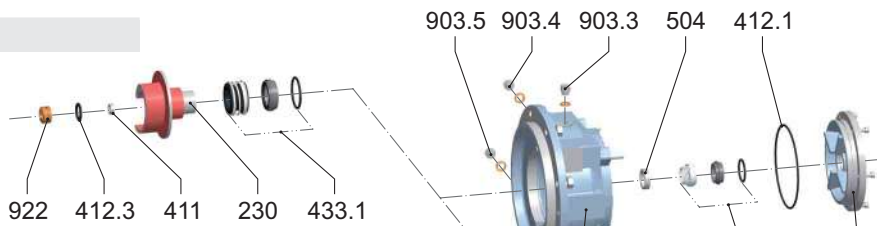

DN 100

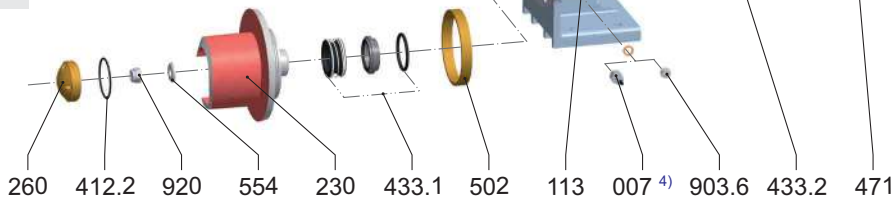

1) Only available for: 1/K50, 2/HK50, 3/HK50, 3/K80, 4/HK80, 5.5/HK80, 15/HK80, 20/HK80, QSH101

4) Special design / accessories

2) DN 80

3) DN 100

Exploded view

Individual components

007	Seal electrode	471	Seal cover
101	Pump casing	502	Casing wear ring
113	Intermediate casing	504	Spacer ring
162	Suction cover	540	Bush
230	Impeller	554	Washer
260	Impeller cap	802	Block motor
320.1	Anti-friction bearing (non drive side)	819	Motor shaft
320.2	Anti-friction bearing (drive side)	831	Fan
400	Gasket	832	Fan hood
400.1	Gasket	903.1	Screwed plug
400.2	Gasket	903.2	Screwed plug
411	Joint ring	903.3	Screwed plug
412.1	O-ring	903.4	Screwed plug
412.2	O-ring	903.5	Screwed plug
412.3	O-ring	903.6	Screwed plug
423	Labyrinth ring	920	Nut
433	Mechanical seal	922	Impeller nut
433.1	Mechanical seal	940	Key
433.2	Mechanical seal		



We reserve the right to make changes in line with technical further developments!



**HERBORNER
PUMPENTECHNIK**